



**Excellent  
low-level  
illumination for  
your stairway,  
with glare-free,  
customizable  
light distribution**



## DESCRIPTION

- The Luz is a low energy LED step light. The Luz offers excellent low level illumination with the ability to place light where needed at time of installation. Intended for concrete pour, brick and block applications. High efficiency LED technology delivers reliable, low maintenance lighting service.
- Unique fixture design allows LED light source to be aimed to fit application, reducing glare or increasing light output as needed.
- Engineered specifically for today's LED technology, the Luz's fixture design provides critical thermal transfer. While most LED step lights trap heat inside, the Luz allows any heat generated to flow away to the cooler outside air. Efficiently removing heat from its LED light source ensures high performance and reliability. Other features include anti-wicking power lead and service upgrade capability.

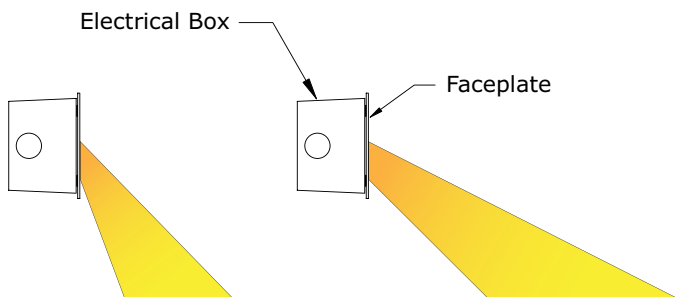

Adjust light distribution to fit application.

## SPECIFICATIONS

<b>Light Source</b>	High-brightness LED
<b>LED Life (L70)</b>	50,000 hours average*
<b>Input Voltage</b>	7 to 15 VAC/VDC
<b>Power Consumption</b>	3.7 Watts
<b>Color Temperature</b>	3000 CCT (K) Typical
<b>CRI</b>	80 Typical
<b>Lens Cover</b>	Acrylic, Impact and UV resistant
<b>Faceplate Material</b>	6061-T6 Aluminum, Brass and Copper
<b>Fasteners</b>	Brass or Stainless Steel Hardware
<b>Standard Mounting</b>	Aluminum Single Gang Die Cast 1/2" Conduit Entries
<b>Operating Temperature</b>	-31F to 122F (-35C to 50C)
<b>Certification</b>	UL1838 (Wet location and concrete pour)



Project
Fixture Type
Prepared By

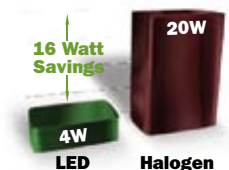

**ENERGY USAGE**

**Luz Uses 80% Less Energy**  
(vs. typical Halogen bulb)

16 Watt Savings

4W LED vs 20W Halogen



\*LED life is defined as the time to 70% lumen maintenance (L70)

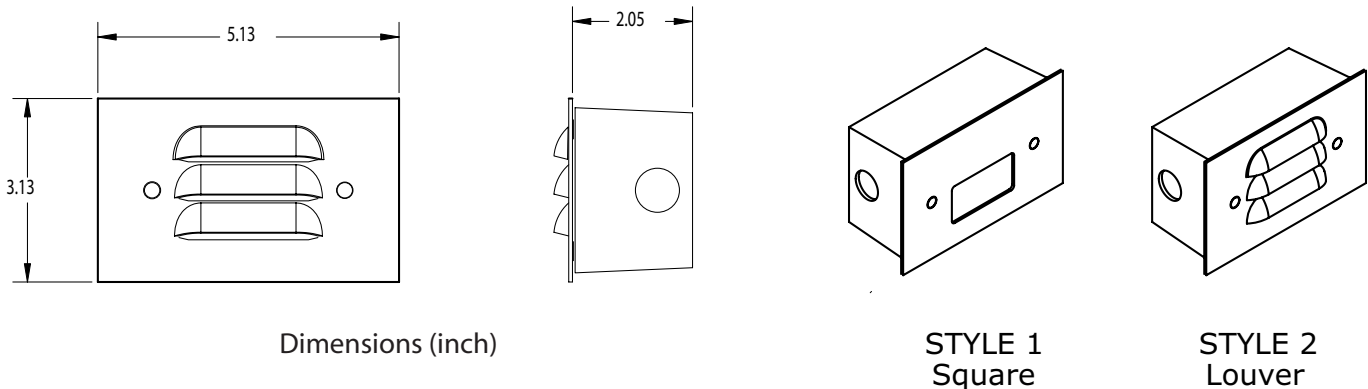

## ORDERING GUIDE

Prefix	Faceplate	Style	Finish
LSL	[AL] Aluminum [BR] Brass [CU] Copper	[1] Square [2] Louver	[ N ] Natural [BK] Powder Coat Black [GR] Powder Coat Green [BN] Powder Coat Brown [CC] Clear Coat [ C ] Custom – Please consult our factory for custom finishes

